

Special H.I.D. lamps

HPA/HPM Metal halide for reprography



HPM 17



HPM 19BT

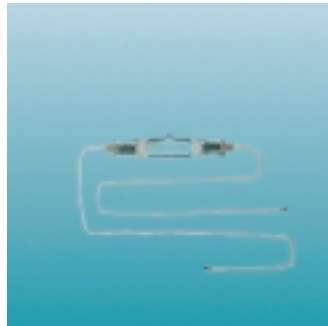

HPA 800R

Single-envelope metal halide UV radiators with additives of iron and cobalt (HPA) or lead and gallium (HPM). Their high quality is expressed in long life, high radiant efficiency, excellent UV output, and arc stability. The spectrum of HPA repro lamps is optimised for UV-A ultraviolet radiation, while HPM repro lamps radiate in the DIAZO range.

These spectra also contain some UV-B and UV-C, which are harmful to eyes and skin. The lamps do not produce ozone. Appropriate measure should be taken to protect eyes and skin against direct irradiation.

Most of the lamps are designed to run at several power levels e.g. standby, medium and full. For optimal operation, the bulb temperature should be kept between 750 and 950° C, with a maximum at the pinches of 350° C. This requires forced air cooling, adapted to the power level.

Applications

Contact copying of images from transparent film to a UV-sensitive carrier e.g. another film, offset plate, silk screen, printed circuit board, microfilm. The type of lamp used depends on the spectral sensitivity of the carrier: UV curing of glue, resin and pigmented lacquer.

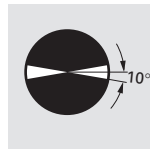

Burning position

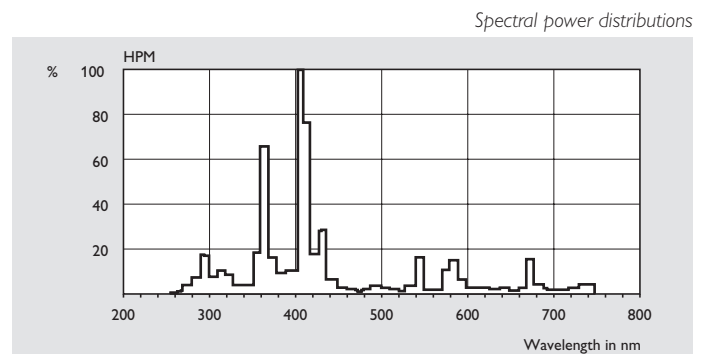
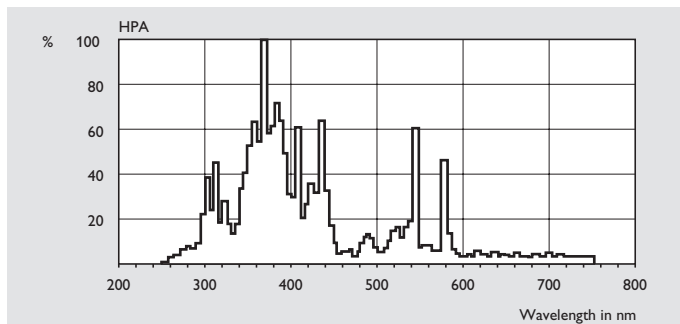

Spectral power distributions

Lamp type	Lamp ¹⁾ wattage	Lamp ¹⁾ voltage	Lamp ¹⁾ current	Run-up time ²⁾ max. min.	UVA irrad. ³⁾ at 0 h $\mu\text{W}/\text{cm}^2$	Diazo irrad. ³⁾ at 0 h $\mu\text{W}/\text{cm}^2$	Mainte- nance ⁴⁾ at 750 h %	Arc length mm	Lamp length ⁵⁾ mm	Lamp diam. mm	Lamp base	Cable length ⁶⁾ mm	Dimensions fig.
HPA 800R	840/430	133/129	7.2/3.8	2	1600		80	37	110	18	C7S	375	1
HPA 1001R	1150/570	130/110	10.0/5.8	2	2000		85	26	137	24	C10.5L	100T	3
HPA 1009R	1150/570	130/110	10.0/5.8	2	2000		85	26	132	24	THS L	100T	4
HPA 1000/20	1100	120	10.5	3	1780		80	21	129	27	C10.5L	100T	2
HPA 1200R	1180/500	125/105	10.5/5.8	3	2240		80	83	147	27	C14X	195	5
HPA 3000R	3000/1575	440/370	8.0/4.8	4	6200		90	105	190	27	C10.5S	110T	8
HPA 4020R	3900/2000	440/410	10.5/5.5	4	8900		90	162	248	27	C10.5S	110T	11
HPA 4048R	3900/2000	440/410	10.7/5.5	4	8900		90	156	242	27	THS S	200T	12
HPA 5035R	4900/2700	255/225	21.0/12	4	10300		90	194	281	24	B14.5	78F	13
HPM 10/B	400	125	3.5	3		700	80	38	112	17	B9.5	-	14
HPM 12	460	120	4.1	5		800	80	45	98	21	C14X	145	15
HPM 13	1000	125	8.6	3		2000	80	76	147	27	C14X	300	16
HPM 15	1950/800	240	9.0	4		4100	90	131	203	32	C14X	300	17
HPM 17	2000	243	8.7	2		4600	80	110	175	27	C14X	300	18
HPM 19BT	2000/900	200	11.0	2		4200	85	103	179	27	B9.5	-	19
HPM 20/B	2900	350	9.4	2		6150	95	150	236	27	B9.5	-	20
HPM 20/C	2900	350	9.4	2		6150	95	150	210	27	C14X	225RT	21
HPM 25/C	5000/1900	245/210	23.0/10	2		12000	90	186	276	27	CU	190	22
HPM 1001	1150/650	120/110	10.0/5.9	2		2800	85	26	137	24	C10.5L	100T	3
HPM 2010	1900/850	210/190	10.0/5.3	2		5600	90	55	132	27	C10.5S	110T	6
HPM 2018	1900/850	210/190	10.0/5.3	2		5600	90	55	132	27	THS S	110T	7
HPM 3000	3350/1575	400/375	9.0/4.8	4		9000	90	105	190	27	C10.5S	110T	8
HPM 3008	3350/1575	400/375	9.0/4.8	4		9000	90	105	190	27	THS S	110T	9
HPM 4010	4000/1800	310/260	13.5/7.4	4		10500	90	117	203	32	C10.5S	190	10
HPM 4020	4000/1850	400/355	11.5/5.8	4		11500	90	162	248	27	C10.5S	110T	11

¹⁾ First electrical value is measured free burning on reference impedance (see table with circuit data) at 0 hours. Second value gives indication of stand-by operation.

²⁾ Maximum time to reach 90% of UV-output after cold start on reference circuit.

³⁾ UV irradiation measured perpendicular to lamp axis at 1 m distance with a relative spectral sensitivity according to IEC. UVA is the wavelength range between 315-400 nm, DIAZO between 320-440 nm.

⁴⁾ Percentage of UV output at 750 h compared to 0 h. The lifetime at which maximum 10% of a large batch of lamps have failed is also specified at 750 h for all HPA/HPM lamps. This lifetime and UV-maintenance is reached under following test conditions:

- Pinch temperature: 350° C max.
- Bulb temperature: 950° C max., 750° C min. (also at reduced power!)
- Switching cycle 5h30' ON, 30' OFF. Horizontal burning position.

⁵⁾ For a definition of Overall Length (OAL), see drawing of lamp base dimensions.

⁶⁾ Cable terminal type: T=straight faston terminal, RT= round terminal, F= flag faston, no symbol= stripped end.

Ordering number Lamp	EOC	Lamp type	Reference ⁷⁾ Impedance Ω	Supply Voltage V	Wiring diagram	Test circuit ⁸⁾				
						B1	B2	B3	B4	Ignitor
9280 564 06000	196125	HPA 800R	20.9 (at 7.5 A)	220	fig.3	BHA 400L08	BHA 400L08	-	-	MZN 1000S
9280 810 06000	194428	HPA 1001R	15.4 (at 10 A)	220	fig.4	BHL 1000L02	BHL 80L11	BTA18L31	BTA58L31	MZN 1000S
9280 824 06000	195876	HPA 1009R	15.4 (at 10 A)	220	fig.4	BHL 1000L02	BHL 80L11	BTA18L31	BTA58L31	MZN 1000S
9280 756 06000	191151	HPA 1000/20	15.4 (at 10 A)	220	fig.4	BHL 1000L02	BHL 80L11	BTA18L31	BTA58L31	MZN 1000S
9280 805 06000	191335	-HPA 1200R	14.6 (at 10 A)	220	fig.3	BHL 1000L02	BHL 250L11	-	-	MZN 1000S
9280 814 06000	194480	HPA 3000R	transformer	380	fig.6	VG12 transformer with C=28 μ F (1800V)				
9280 812 06000	194275	HPA 4020R	transformer	380	fig.6	VG12 transformer with C=36 μ F (1800V)				
9280 832 06000	196828	HPA 4048R	transformer	380	fig.6	VG12 transformer with C=36 μ F (1800V)				
9280 503 06000	194213	HPA 5035R	10.8 (at 25 A)	380	fig.5	BHL 2000L18	BHL 2000L18	BHL 700L02	BHL700L02	380MZN 4000
9280 706 05100	190499	HPM 10/B	44.9 (at 3.5 A)	220	fig.2	BHL 400L11	-	-	-	SU 40S
9280 729 05100	190581	HPM 12	39 (at 4.6 A)	220	fig.1	BSN 400L08	-	-	-	SN58
9280 744 05100	190642	HPM 13	18.7 (at 7.5 A)	220	fig.2	BHL 1000L02	-	-	-	MZN 1000S
9280 728 05100	191489	HPM 15	28 (at 8 A)	380	fig.2	BHL 2000L18	-	-	-	380 MZN 4000
9280 727 05100	190550	HPM 17	28 (at 8 A)	380	fig.2	BHL 2000L18	-	-	-	380 MZN 4000
9280 748 06000	190703	HPM 19BT	26.4 (at 11 A)	380	fig.5	BHL 2000L18	-	BHL 80L11	BHL 80L11	380 MZN 4000
9280 746 05100	190673	HPM 20/B	transformer	380	fig.6	VG12 transformer with C=24 μ F (1800V)				
9280 766 05100	190796	HPM 20/C	transformer	380	fig.6	VG12 transformer with C=24 μ F (1800V)				
9280 792 06000	191762	HPM 25/C	10.8 (at 25 A)	380	fig.5	BHL 2000L18	BHL 700L02	BHL 700L02	BHL 700L02	380 MZN 4000
9280 811 06000	194305	HPM 1001	15.4 (at 10 A)	220	fig.4	BHL 1000L02	BHL 80L11	BTA18L31	BTA58L31	MZN 1000S
9280 808 06000	194336	HPM 2010	31.8 (at 9.5 A)	380	fig.2	BHL 2000L29	-	-	-	380 MZN 4000
9280 830 06000	196804	HPM 2018	31.8 (at 9.5 A)	380	fig.2	BHL 2000L29	-	-	-	380 MZN 4000
9280 813 06000	194367	HPM 3000	transformer	380	fig.6	VG12 transformer with C=28 μ F (1800V)				
9280 826 06000	195999	HPM 3008	transformer	380	fig.6	VG12 transformer with C=28 μ F (1800V)				
9280 794 06000	191007	HPM 4010	transformer	380	fig.6	* on request*				
9280 807 06000	194398	HPM 4020	transformer	380	fig.6	VG12 transformer with C=36 μ F (1800V)				

⁷⁾ For inductive circuits, the impedance of the ballast is given.
For transformer type circuits, see Test circuit.

⁸⁾ The four ballast test circuits are only given for design purposes.

A custom designed ballast is preferred in practice. With two ballast systems, one of the ballasts may be switched to achieve stand-by operation.

Wiring diagrams

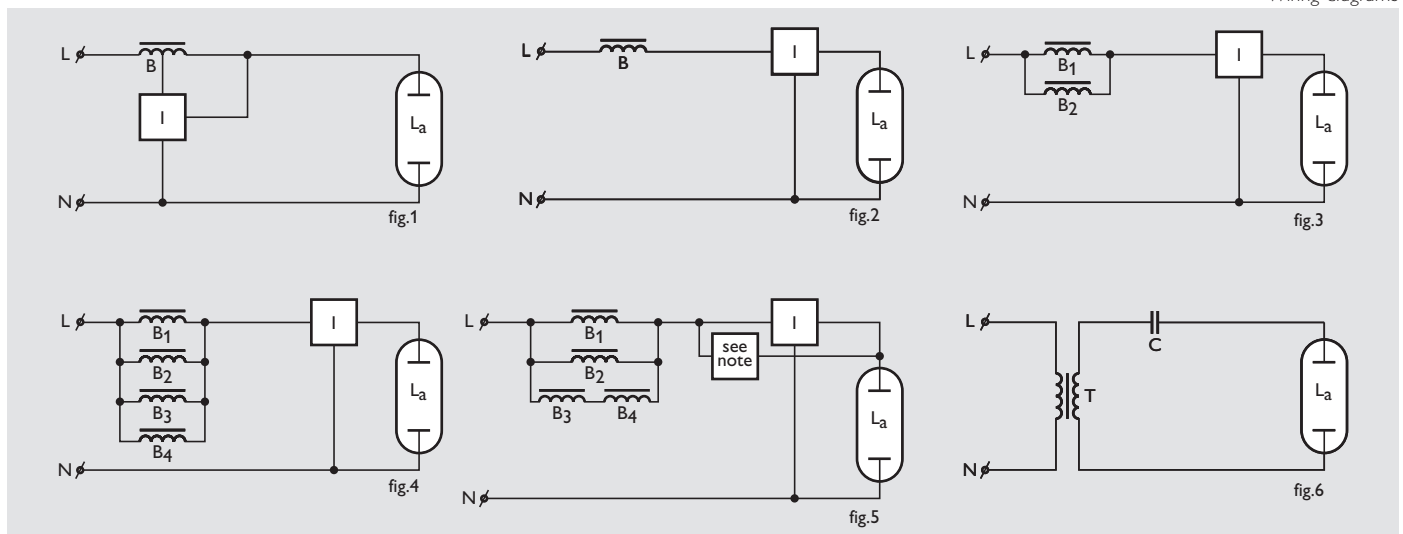

Max. current of 380 MZN 4000 ignitor is 18 A. For lamps with a higher lamp current (HPM 25C, HPM 5005, HPA 5035R): place a second ignitor in parallel, or bridge the ignitor with a switch closing immediately after ignition.

Special H.I.D. lamps

HPA/HPM Metal halide for reprography

Dimensions in mm

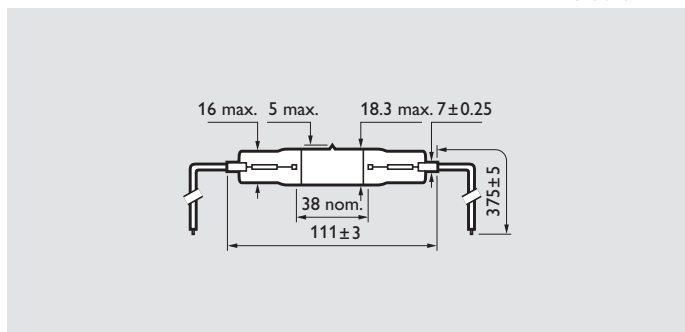
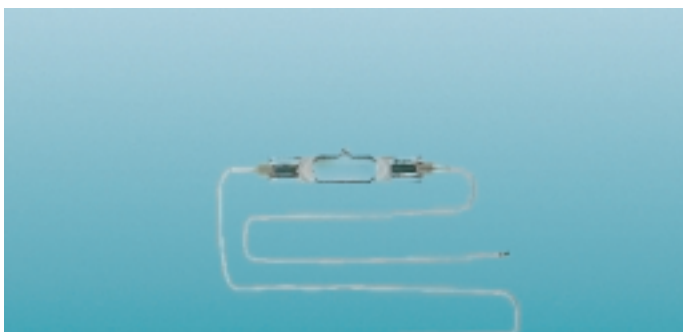

Fig. 1 HPA 800R

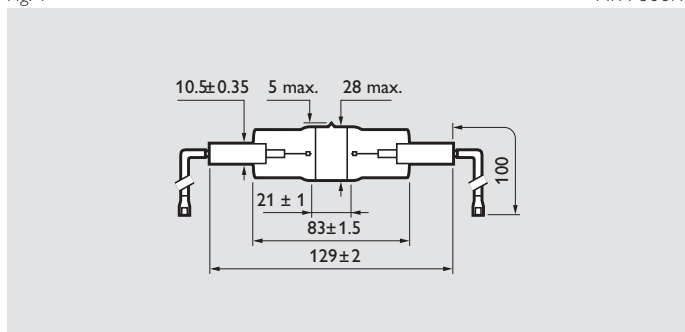

Fig. 2 HPA 1000/20

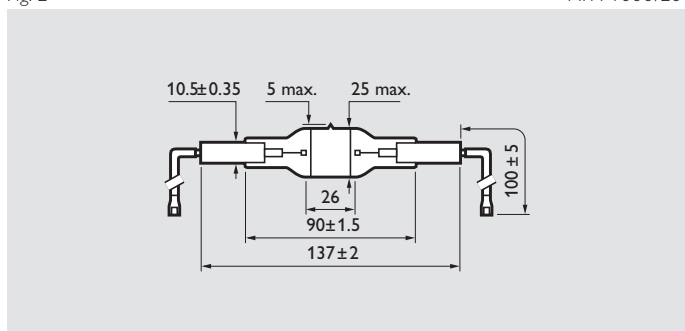

Fig. 3 HPA 1001R, HPM 1001

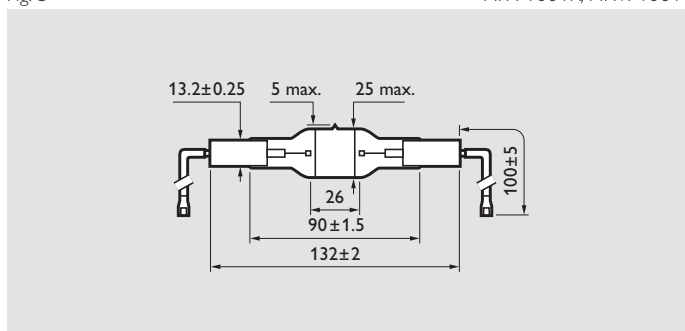

Fig. 4 HPA 1009R

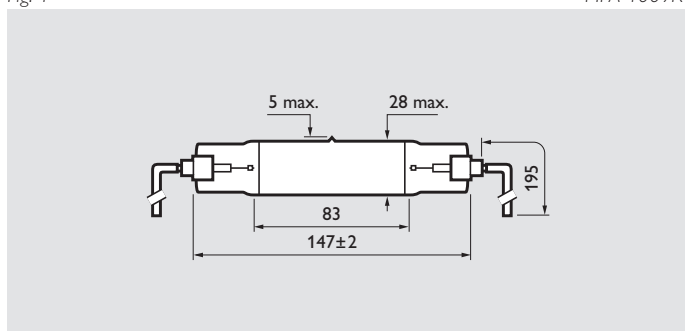

Fig. 5 HPA 1200R



Special H.I.D. lamps

HPA/HPM Metal halide for reprography

Dimensions in mm

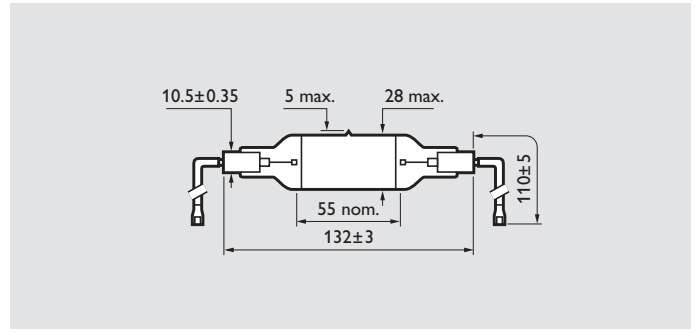

Fig. 6 HPM 2010

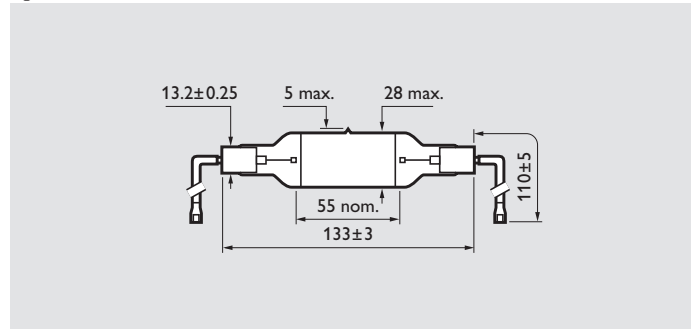
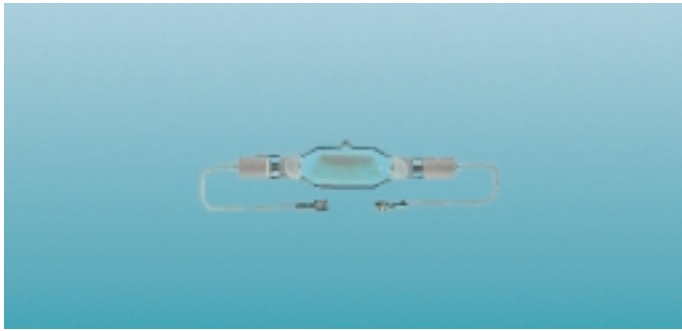

Fig. 7 HPM 2018

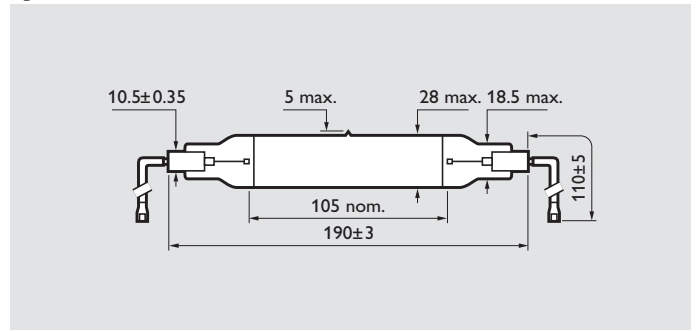
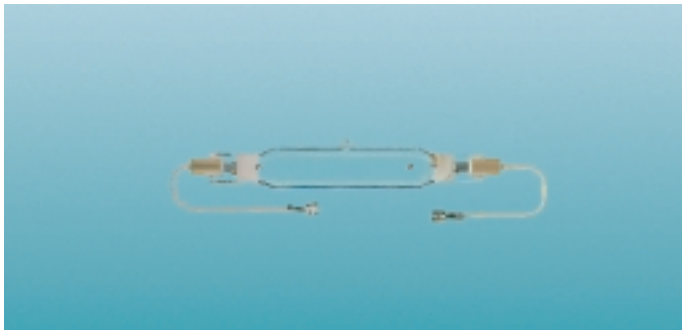

Fig. 8 HPA 3000R, HPM 3000

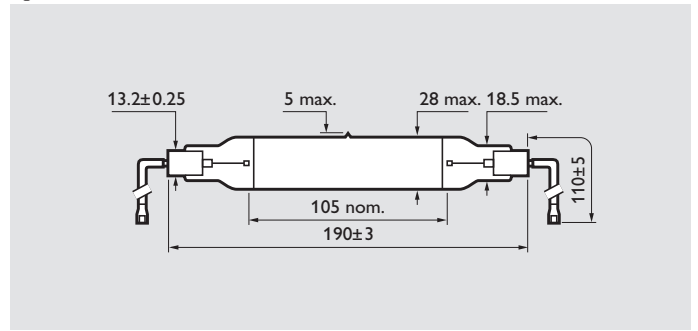
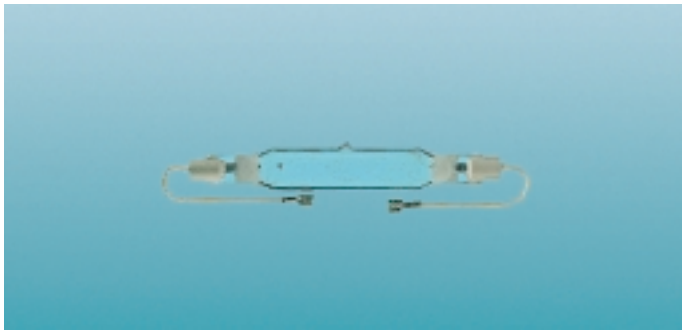

Fig. 9 HPM 3008

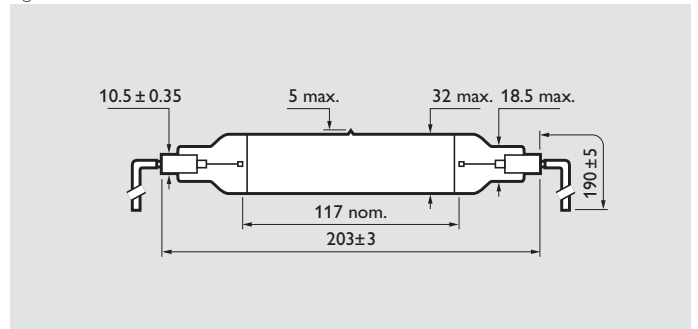

Fig. 10 HPM 4010 (HPM 30)



Special H.I.D. lamps

HPA/HPM Metal halide for reprography

Dimensions in mm

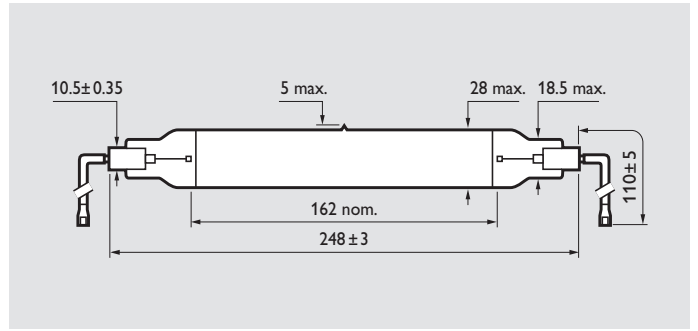
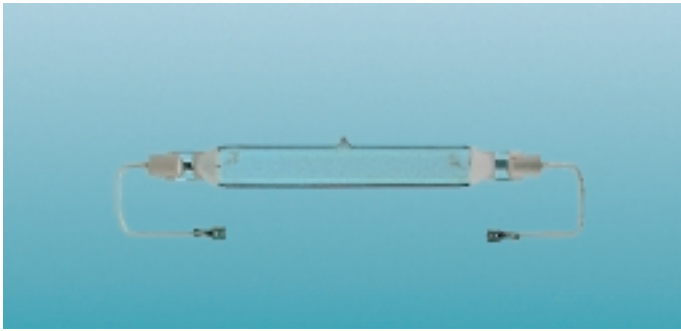

Fig. 11 HPA 4020R, HPM 4020

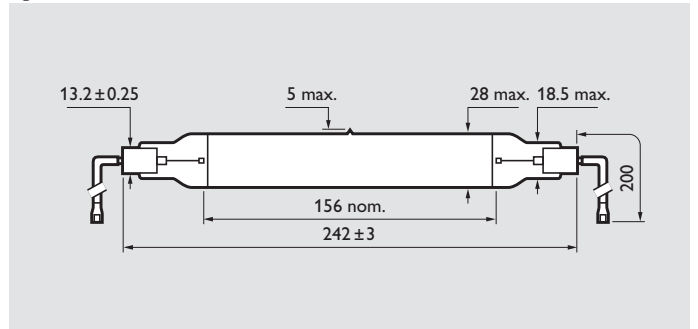

Fig. 12 HPA 4048R

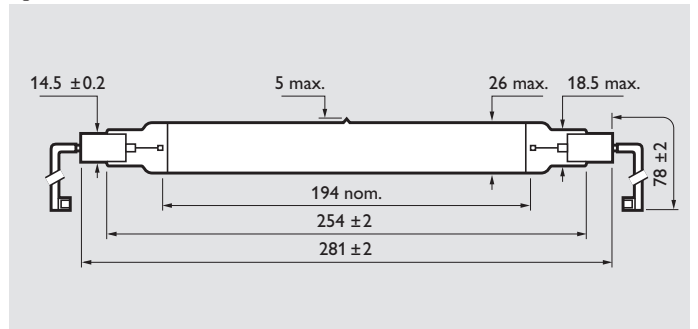
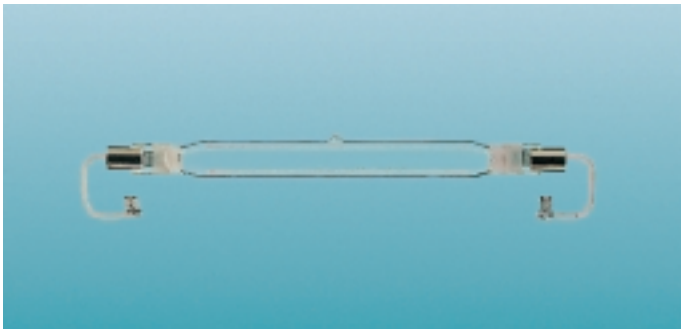

Fig. 13 HPA 5035R

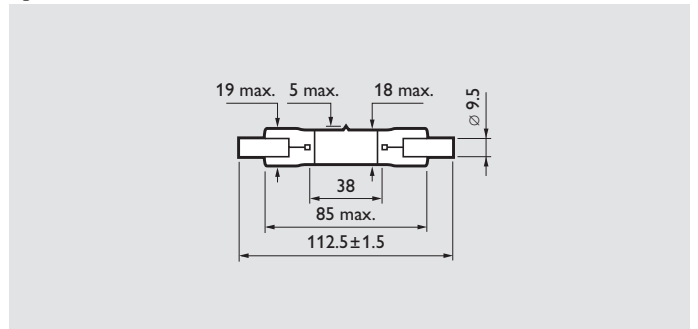
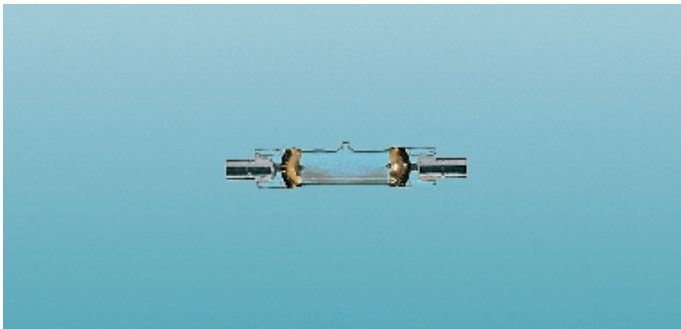

Fig. 14 HPM 10/B

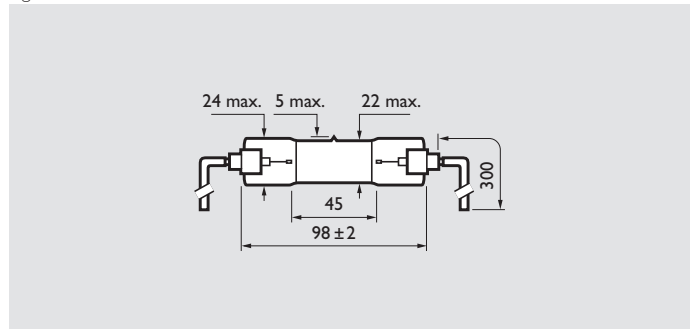
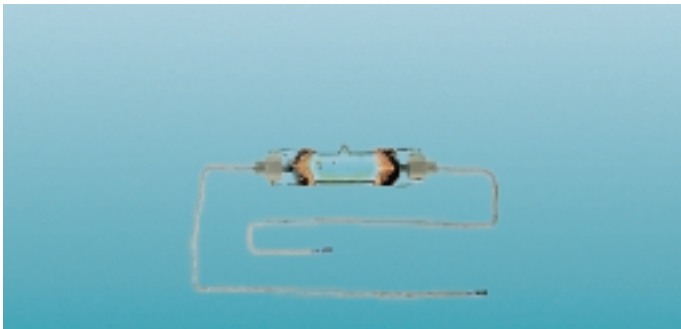

Fig. 15 HPM 12



Special H.I.D. lamps

HPA/HPM Metal halide for reprography

Dimensions in mm

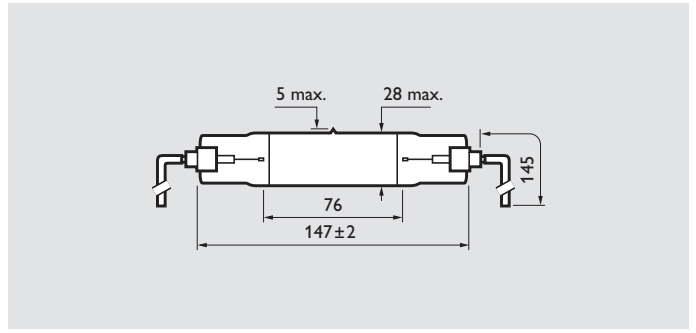
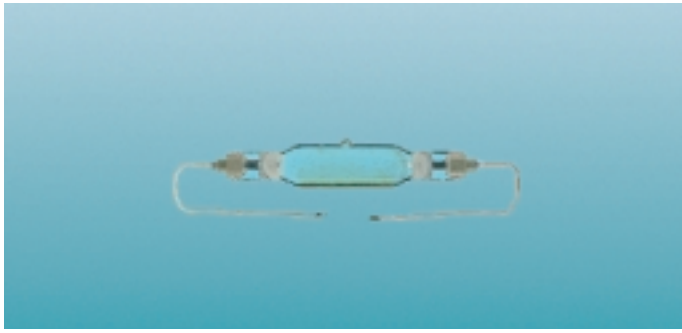

Fig. 16

HPM 13

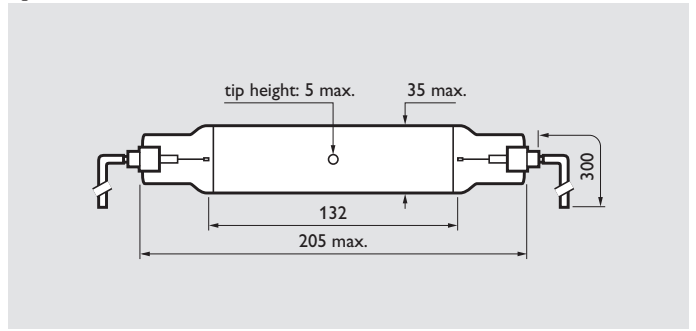
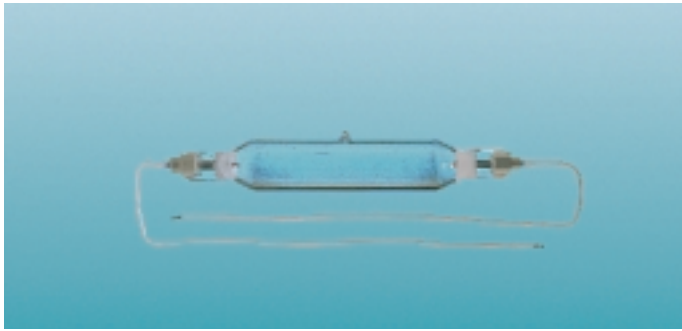

Fig. 17

HPM 15

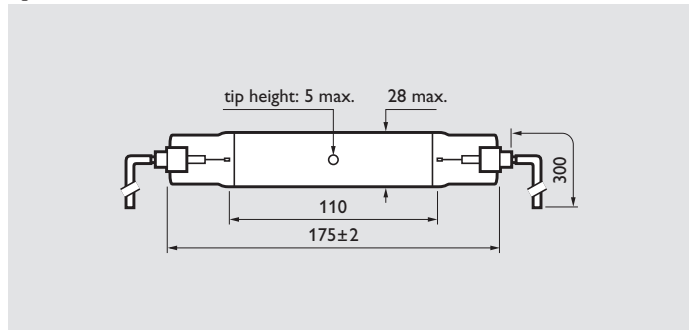
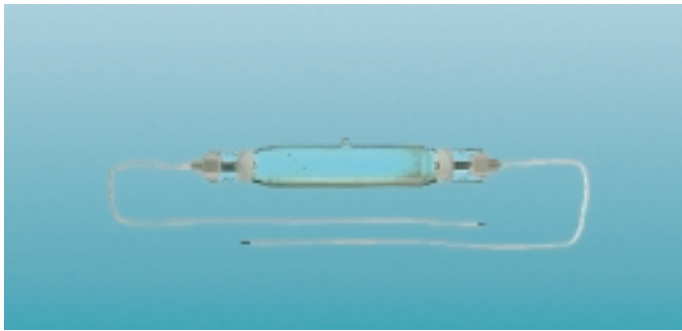

Fig. 18

HPM 17

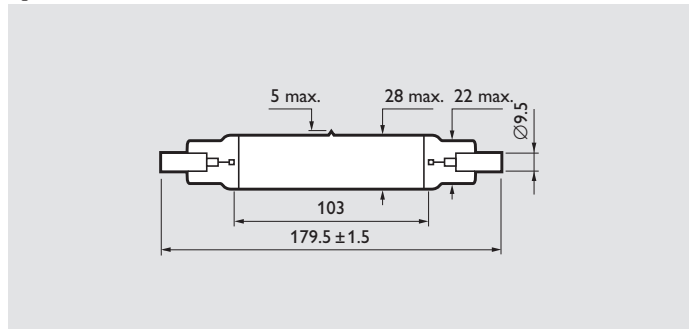

Fig. 19

HPM 19BT

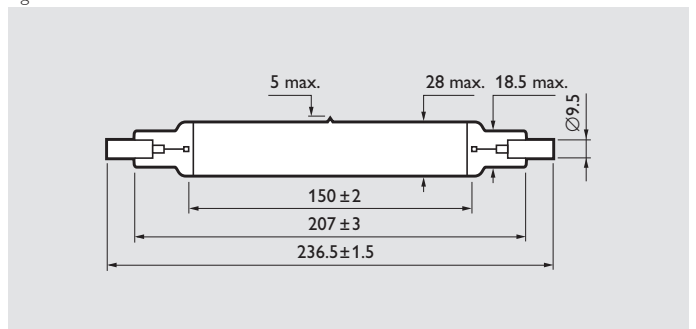

Fig. 20

HPM 20/B



Special H.I.D. lamps

HPA/HPM Metal halide for reprography

Dimensions in mm

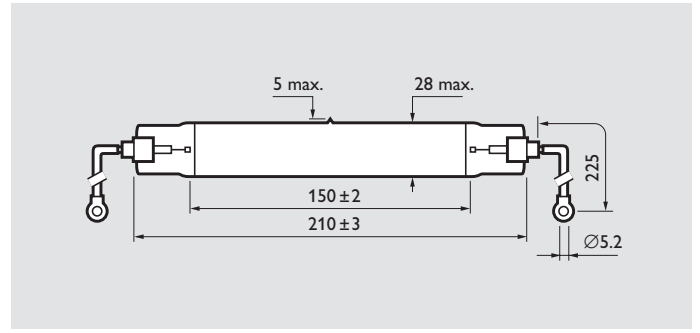
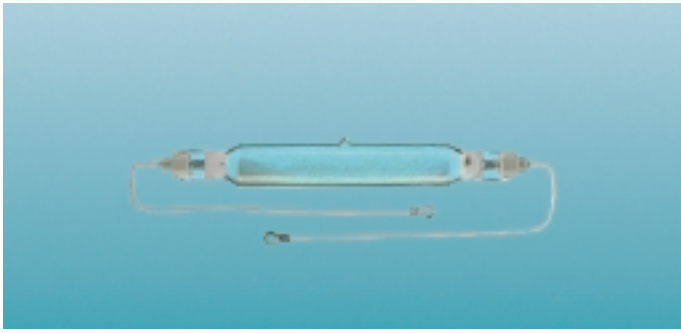

Fig. 21

HPM 20/C

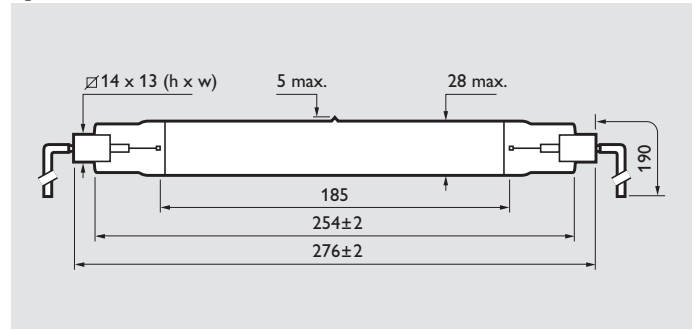
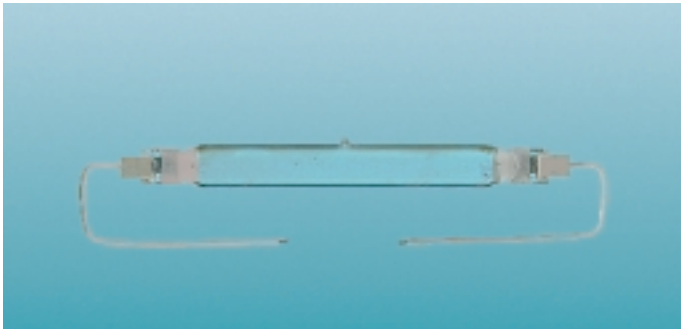
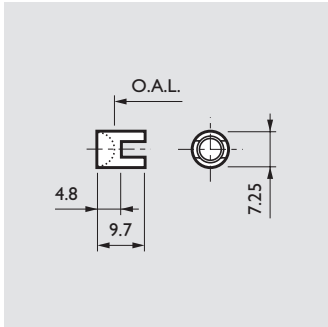

Fig. 22

HPM 25/C

Lamp base material is ceramic, except B-types which are in metal



R7s

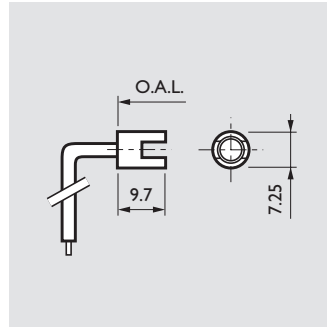

C7s

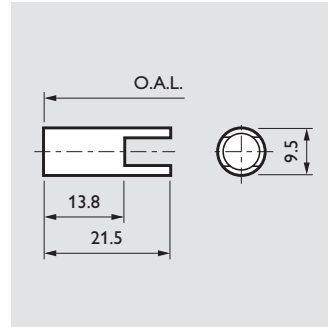

B9.5

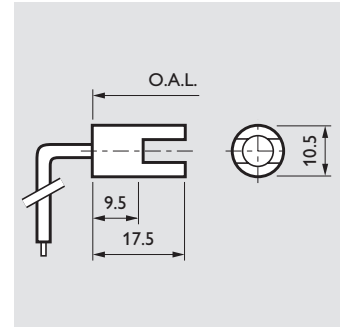

C10.5s

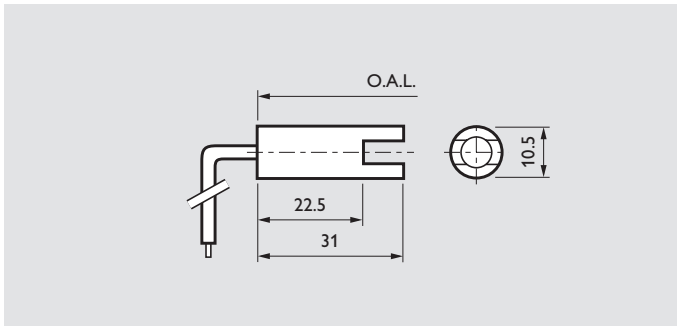

C10.5L

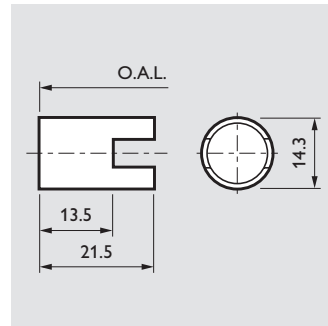

B14.5

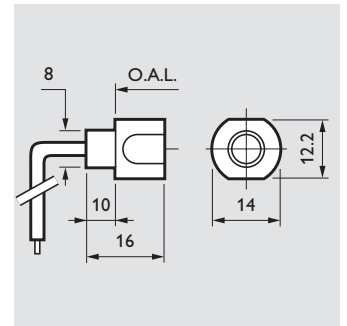

C14X

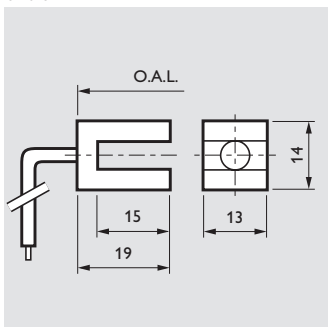

CU
8

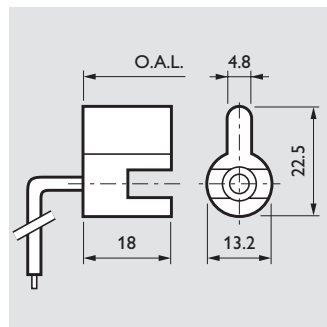

THS-S

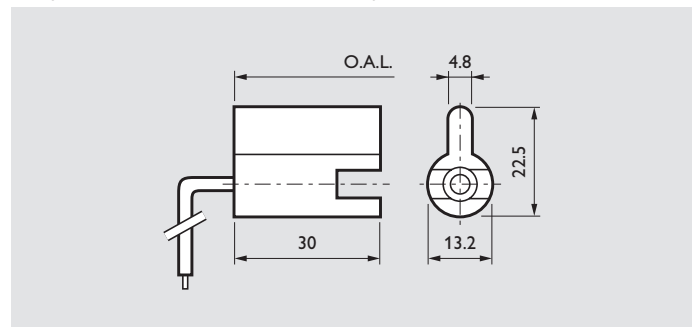

THS-L



PHILIPS